

Pumps



EcoVISE variable speed pump 0.75 kW

Three selectable program speeds ensure silent operation, energy savings and more efficient filtration. Built on the same design and performance as WaterVISE, with a high efficiency, motor. Integrated timer functions and external control of selected speeds.

Technical data

| Item no. | Type | Voltage/Ampere | | | | kg |
|----------|------|----------------|--------|--------|--------|----|
| | | kW 50Hz | 3~230V | 1~230V | 3~400V | |
| 117103 | HV75 | < 0.75 | - | 4.4 | - | 13 |

Accessories

Item no.

| | |
|--------|---------------------|
| 117100 | External switch Eco |
|--------|---------------------|

Features

- WaterVISE design and performance
- High efficiency, synchronous motor
- Three adjustable selectable program speeds
- Timer functions for flexible operating conditions
- External speed control as accessories
- Maximum energy savings

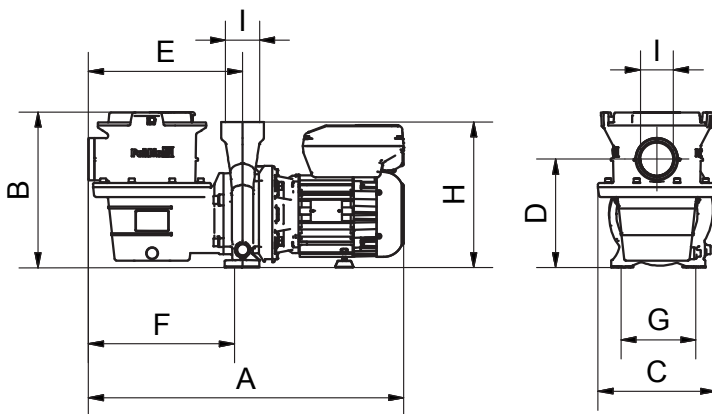

Pump capacities

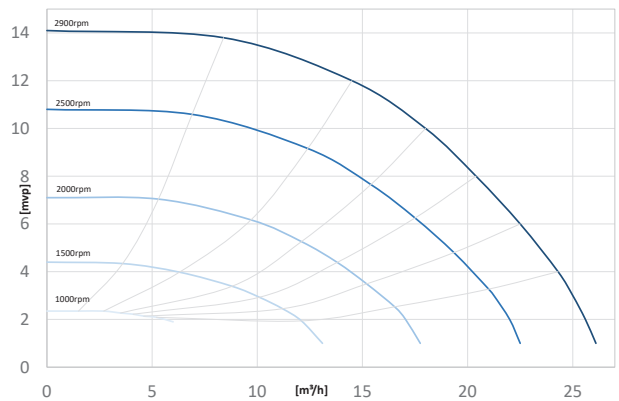

Dimensions

| Item no. | Type | A | B | C | D | E | F | G | H | I |
|----------|------|-----|-----|-----|-----|-----|-----|-----|-----|----|
| 117103 | HV75 | 525 | 280 | 196 | 181 | 257 | 239 | 125 | 243 | 2" |